

CASTER PAD INSTALLATION INSTRUCTIONS: RFM-3C-30 (RFM SERIES 30 CABINETS) RFM-3C-24 (RFM SERIES 24 CABINETS)

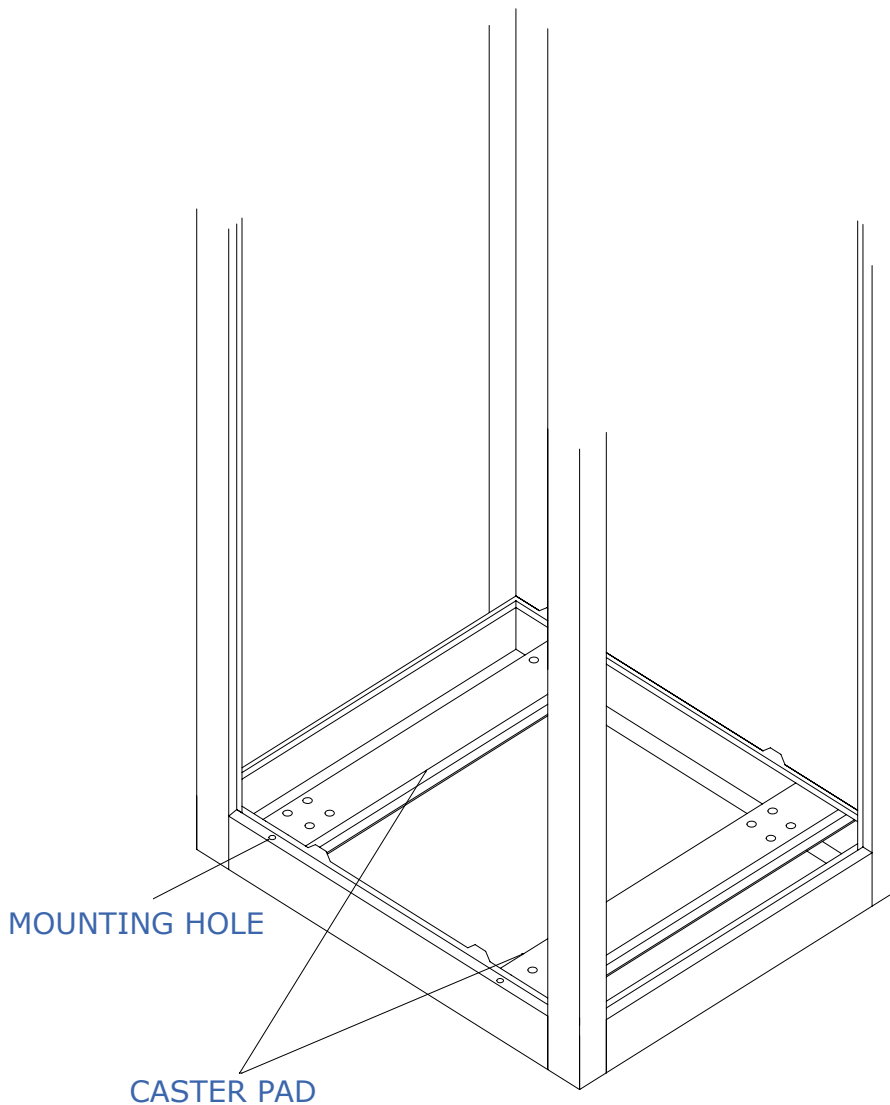

STEP 1:

IF EQUIPPED, REMOVE END PANELS FROM CABINET

STEP 2:

NOTE: THERE ARE 2 MOUNTING HOLES IN THE CABINET BASE FLANGE WHICH THE SIDE PANELS SIT ON. (*SEE DIAG.*)

STEP 3:

NOTE: THERE ARE 2 MOUNTING HOLES IN EACH CASTER PAD, EACH WITH A NUT ATTACHED ON THE UNDERSIDE.

STEP 4:

WITH THE ATTACHED NUT FACING THE UNDERSIDE, POSITION THE CASTER PAD UNDER THE FLANGE IN THE BASE OF THE CABINET AND LINE UP THE MOUNTING HOLES (*SEE DIAG.*)

STEP 5:

ENSURE THE HOLE IN THE CABINET BASE FLANGE AND THE NUT ON THE BOTTOM OF THE CASTER PAD ARE ALIGNED, AND FASTEN USING THE SUPPLIED SCREW

STEP 6:

REPEAT, FROM STEP 4, WITH REMAINING HOLES UNTIL CASTER PADS ARE SECURED TO CABINET